

Variety Store

Spectrum[®]

HO SCALE

cityscenes[™]

ASSEMBLY INSTRUCTIONS



Item #88004

PLACEMENT LAYOUT

1. Place Assembled Roof Access Door on location as shown.

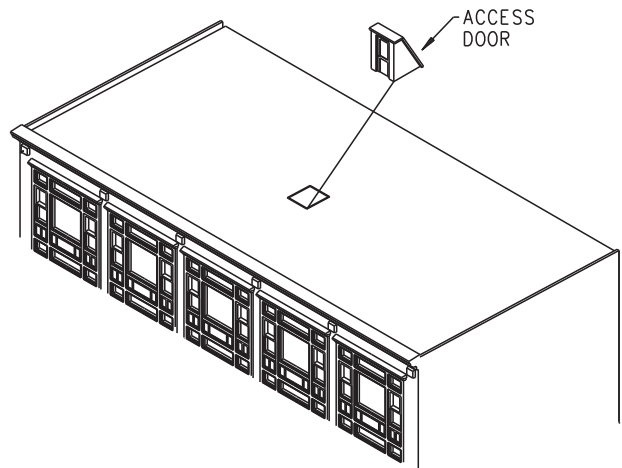

MAILBOXES

1. Assemble Mailbox Halves (6) and (7).

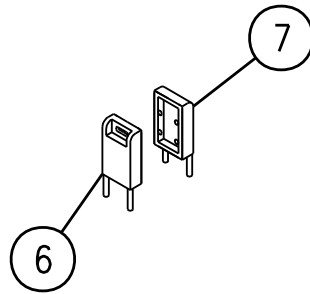

ROTARY EXHAUST VENTS

1. Assemble Roof Vent (9) to Base (10).

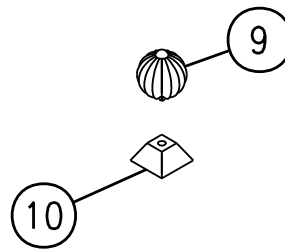

front wall sub assembly

Assemble all parts to BACKSIDE of the Walls. When properly positioned, the Clear Parts fit onto locator tabs extending from Wall. All Window Clear Parts are marked "**THIS SIDE UP**." For proper assembly, be sure "**THIS SIDE UP**" is facing you and legible when assembling.

ASSEMBLE IN SEQUENCE:

1. Top Front Wall Filler (22) into Front Wall (2). **NOTE:** The protrusions on the Top Front Wall Filler (22) face INTO recess on Wall (22). The Top Front Wall Filler is required due to technical restrictions in the molding process.
2. Two Doorways (14) into openings on Front Wall (2).
3. Two pieces of Clear Parts (21) onto locator tabs of two Doors (14).
4. Thirteen pieces of Clear Parts (20) onto locator tabs on Rear Wall. The Clear Parts are used on the Ground, First, and Second Floors.

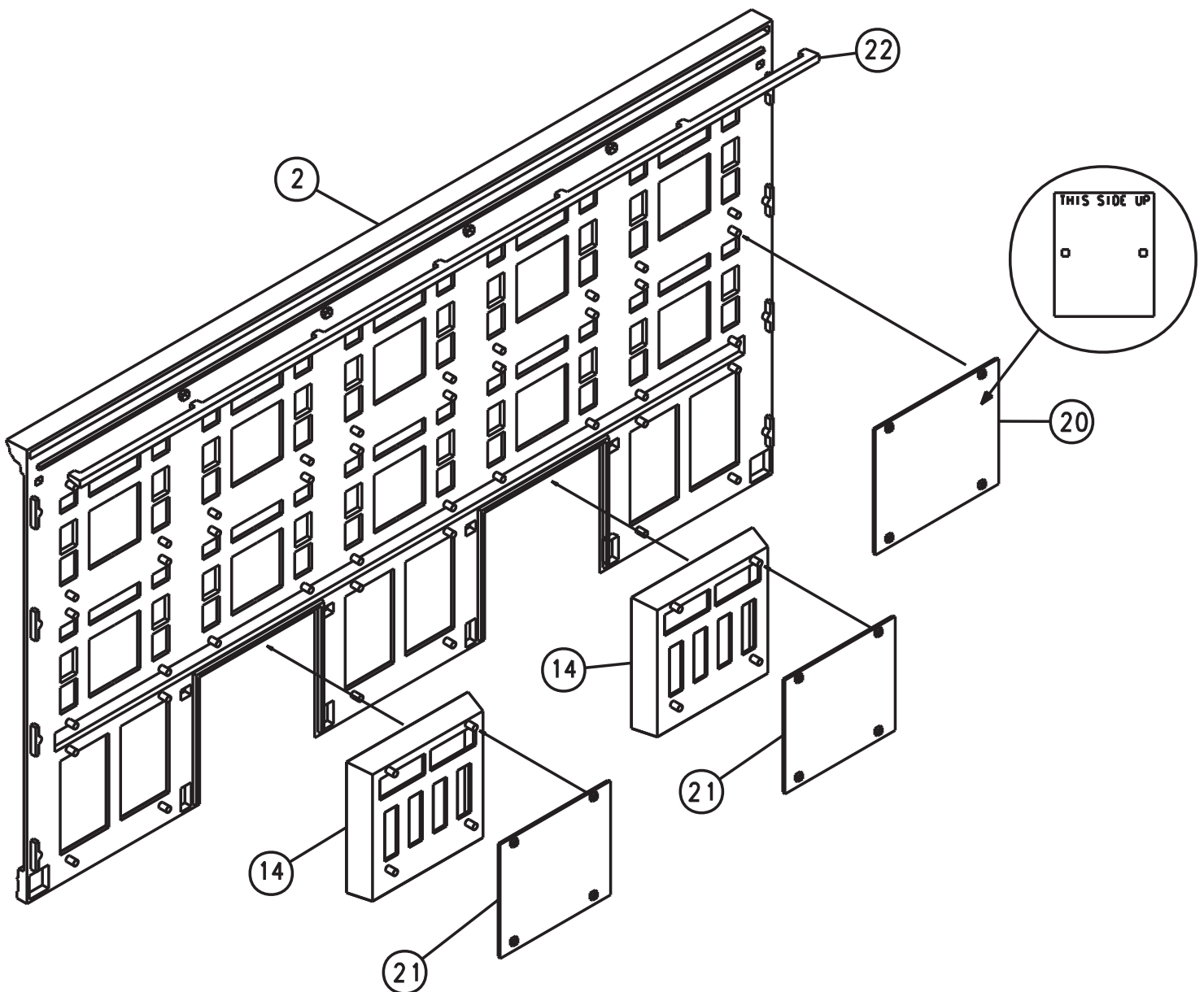

sidewalk assembly

Depending on the location of this building on your layout, you have the option of placing Sidewalks on one, two, three, or four sides of this building. Cut each Sidewalk section (88) to the proper length for an appropriate fit. Use Corners (89) to connect the straight Sidewalk sections (88).

NOTE: The Sidewalks included with this kit are compatible with the Street and Sidewalk System made by Wm. K. Walthers Co. Milwaukee, WI.

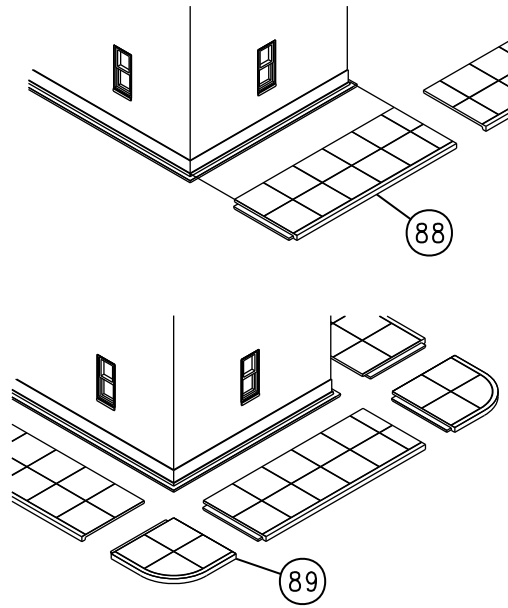

final building assembly

When assembling Walls, carefully align Wall tabs with each Wall. Dry fit each part before applying glue. Apply glue sparingly on the assembly tabs and lower backside edge of Wall.

ASSEMBLE IN SEQUENCE:

1. Front Wall (2) to Base (1).
2. Right Side Wall (3) to Base (1) and Front Wall (2).
3. Back Wall (5) to Base (1) and Wall (3).
4. Left Side Wall (4) to Base (1) and Front Wall (2) and Back Wall (5).
5. Roof (6) to all four Walls. **NOTE:** Assembly tabs of Roof (6) attach to Back Wall (5).

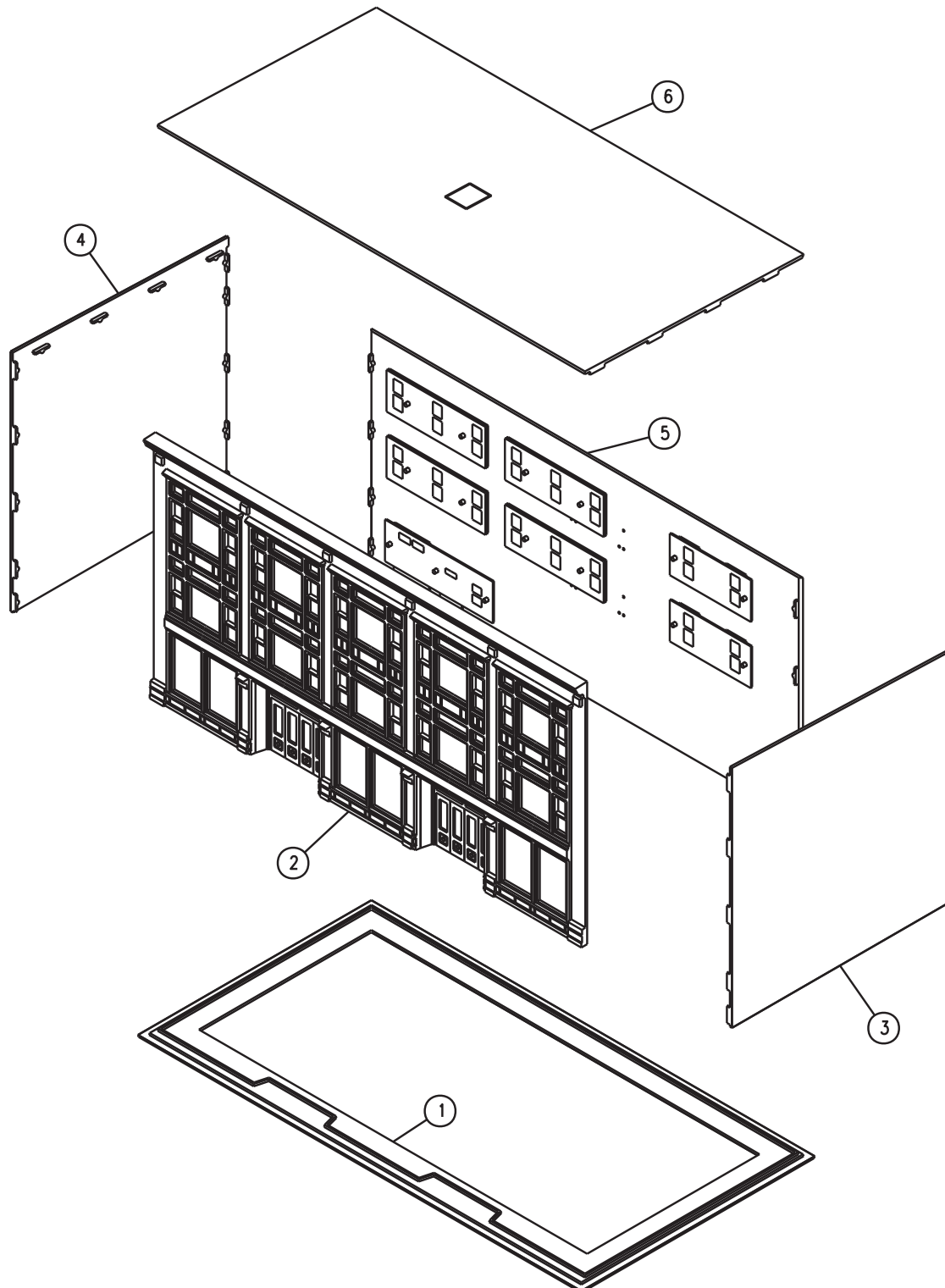

brick trim and canopy assembly

The Brick Trim has been manufactured to authentic scale. When removing the parts from the sprue, CAREFULLY cut, not break, the parts from the sprue. To clean away the flash, use a piece of sandpaper with a "FINE" grit or an emery board. This will keep all of the edges straight and avoid gouging.

Parts are assembled onto FRONT side of Wall (2). All parts, especially the Brick Trim, have been designed for a snug fit. Use glue sparingly.

ASSEMBLE IN SEQUENCE:

1. Brick Trim (9) into recess on Front Wall (2).
2. Four pieces of Brick Trim (8) into recesses on Front Wall (2).
3. Canopy (10) onto Front Wall (2).
4. Two pieces of Brick Capping Trim (7) onto top edge of Right and Left Side Walls (3) and (4), respectively.

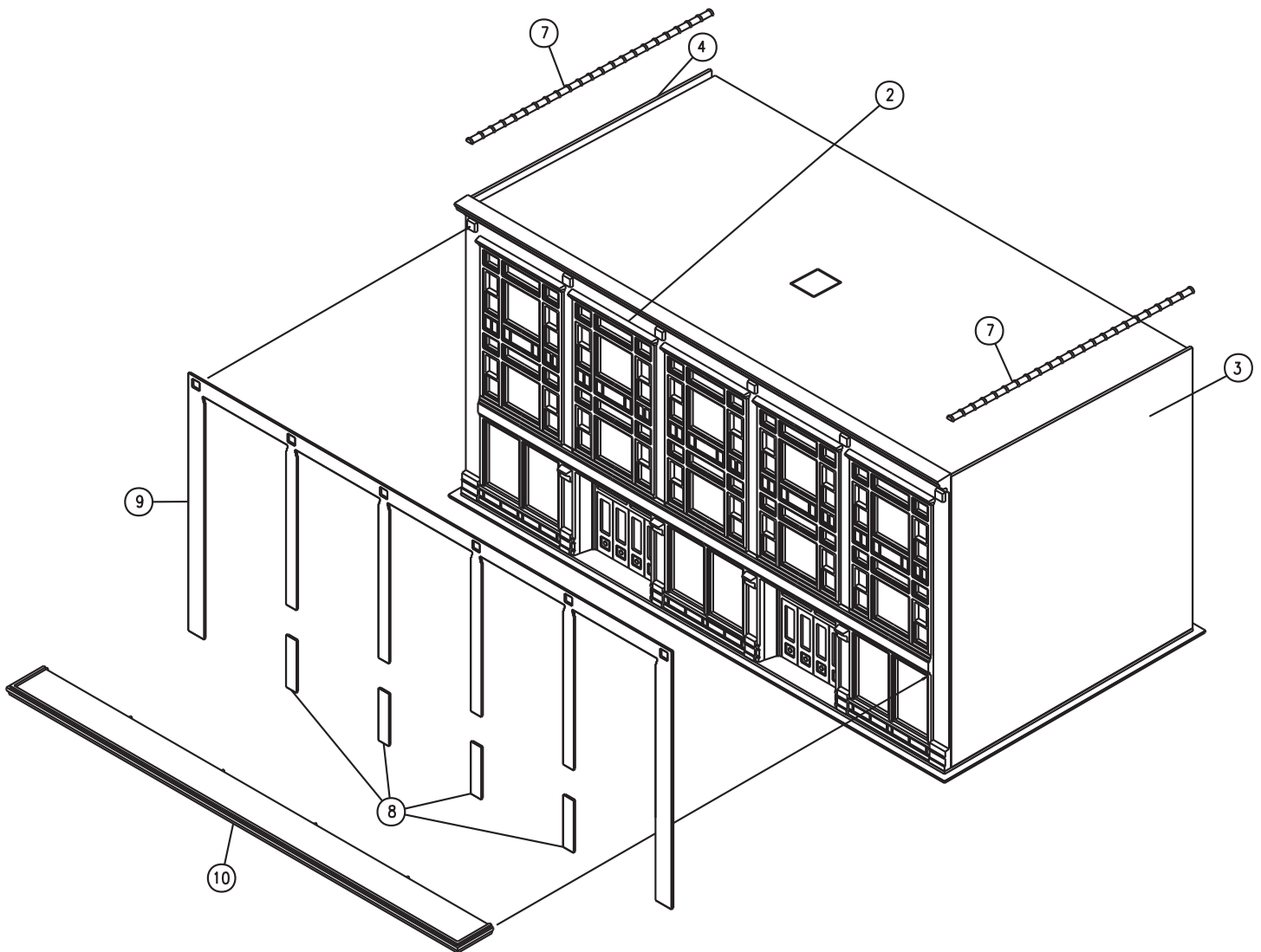

detail parts and accessory assemblies

FIRE ESCAPES:

NOTE: For proper positioning, make sure that tabs that fit into the Wall are all assembled facing outward in the same direction.

ASSEMBLE FOUR FIRE ESCAPES:

1. Assemble Side Railing (92) to Floor Railing (91).
2. Assemble End Railings (93) to Floor Railing (91) and Side Railing (92).
3. After glue has dried on these assemblies, the Fire Escapes can be mounted into the Back Side locator holes opened during Back Wall assembly.
4. After assembling to Wall, place Ladders (94) and (95) into position on the Fire Escapes.

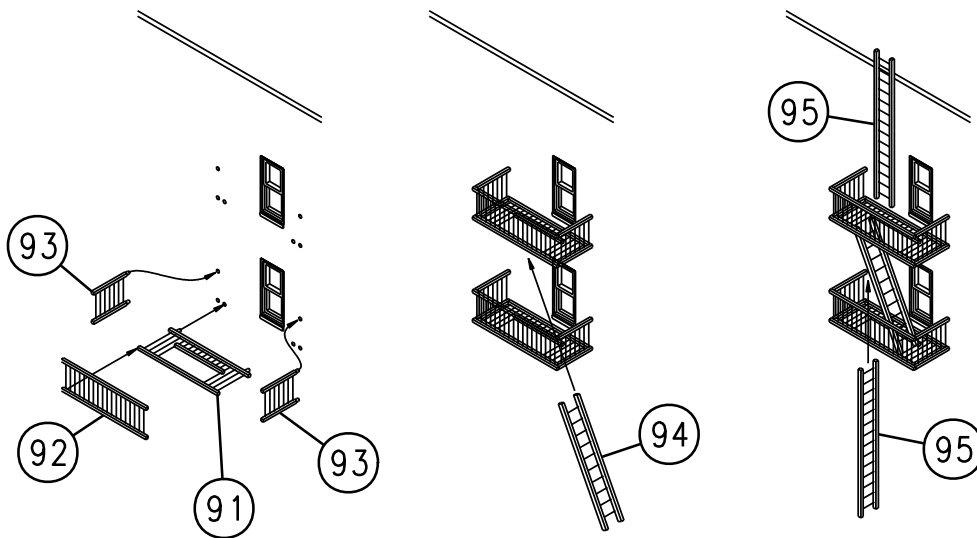

back wall assembly

FIRE ESCAPES - WALL LOCATOR HOLES:

On the Back Wall (5), locator holes have been designated with, "**Optional Holes for Fire Escape.**" If you intend to assemble the Fire Escapes to the Back Wall, drill out holes prior to window assembly. Drill from the back side, using a .039 (#61) drill bit. You may also use a hobby knife to open the holes, but take care not to make these holes oversized.

WINDOW AND DOOR SUB ASSEMBLY:

Assemble all parts to BACKSIDE of the Wall. When properly positioned, the Window fits solidly into wall window opening; the Clear Part(s) fit onto locator tabs extending from Wall, and trap the windows in place. If desired, use glue on Windows and Clear Parts.

ASSEMBLE IN SEQUENCE:

1. Freight Door (11) into opening Back Wall (5).
2. Employee Door (12) into opening Back Wall (5).
3. Small Window (13) into opening Back Wall (5).
4. Clear Part (19) onto locator tabs on Back Wall (5). Clear Part (19) covers Doorways (11) and (12) and Small Window (13).
5. Four pieces of Window Panel (16) into Back Wall (5).
NOTE: Each Window Panel (16) contains three Windows.
6. Four pieces of Clear Part (17) onto locator tabs of Back Wall (5).
NOTE: Each Clear Part (17) covers all ONE window Panel (16).
7. Four Single Windows (15) into openings of Back Wall (5).
8. Two Clear Parts (18) onto locator tabs of Back Wall (5).
NOTE: Each Clear Part (18) covers TWO Single Windows (15).

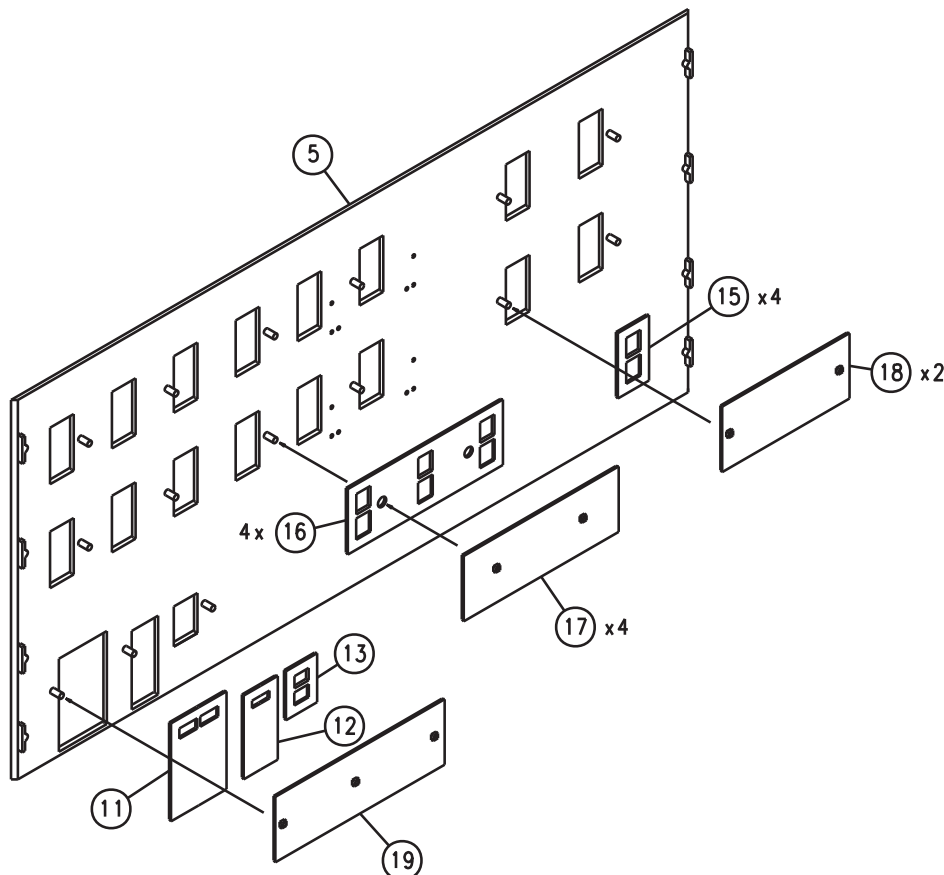

roof and sidewalk detailing accessories

Your kit comes complete with optional Roof and Sidewalk Detailing Accessories. Some, such as Roof Vents Parts (11) and Fire Hydrants Parts (8), do not require assembly. Others require assembly as shown.

After assembly, position the accessories on or around your building as required.
Suggested locations:

BUILDING ROOF TOP

Elevator Shaft Access Panel
Rotary Exhaust Vents
Water Tank
Roof Vents

SIDEWALK

Mail/Express Boxes
Fire Hydrants

NOTE: Dry Fit each part before assembly. Glue should be applied sparingly to the assembly tabs.
For added detail, parts can be individually painted before assembly.

ELEVATOR SHAFT ACCESS PANEL

ASSEMBLE IN SEQUENCE:

1. Side Panel (2) to Panel (3).
2. Side Panel (4) to Panel (3).
3. Front Panel (5) to Side Panel (2) and (4).
4. Roof (1) to Walls (2), (3), (4), and (5).

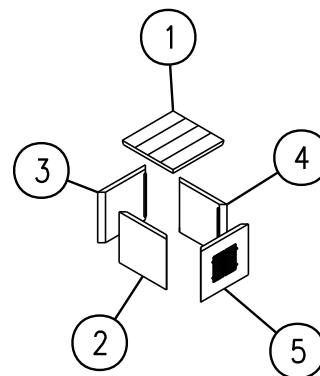

ROOF ACCESS DOOR

NOTE: Glue should be applied sparingly to all parts.

ASSEMBLE IN SEQUENCE:

1. Door (12) to Wall (13).
2. Wall (15) to Front Wall (13).
3. Wall (16) to Front Wall (13).
4. Roof (14) must be bent slightly downward to the contours of Walls (13), (15), and (16). Once bent, assemble Roof (14) to Walls (13), (15), and (16).

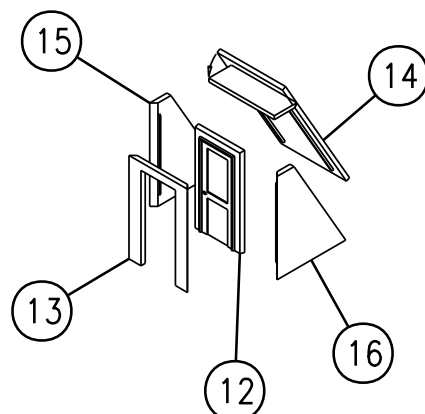

READ PRIOR TO ASSEMBLY

TO ENHANCE THE AESTHETIC AND REALISTIC QUALITIES OF THIS BUILDING, PARTS HAVE BEEN DESIGNED AND MANUFACTURED IN SCALE PROPORTIONS. AS A RESULT, SOME PARTS ARE FRAGILE AND REQUIRE CARE IN ASSEMBLY. THEREFORE... EASY DOES IT. AS WITH ANY MODEL BUILDER KIT, A DEGREE OF PATIENCE IS REQUIRED TO ACHIEVE THE BEST RESULTS.

ASSEMBLY HINTS

- Read through these instructions and examine the parts supplied to familiarize yourself with all aspects of the building prior to assembly.
- Remove the parts as needed, not at random.
- To remove the parts from the sprues, cut, not break, each part.
- However, when removing Clear Parts from the sprue, bend the Clear Part back and forth. The bending action will safely remove part from sprue.
- If you choose to paint any parts, we suggest you do so prior to assembly.
- To ensure a nice, tight fit, carefully remove all excess sprue marks with a modeling knife or hobby file. This is a necessity or parts will not fit properly.
- Follow the sequence guide to ensure correct placement of the parts.
- VERY IMPORTANT - Before gluing, dry fit the parts.
- Use glue sparingly, especially when assembling Window Frames and Clear Parts. These parts have been designed to tight tolerances, in many cases enabling you to trap the Window Frames between the Wall and the Clear Part, and therefore require only "tack" gluing.
- All Window Clear Parts are marked "**THIS SIDE UP.**" For proper assembly, be sure "**THIS SIDE UP**" is facing you and legible when assembling. This will properly orient the part to slide easily onto locator tabs.
- Prior to assembling a Window Clear Part, be sure you have matched "Open" and "Closed" Window Frames with "Open" and "Closed" (solid) Clear Parts (if applicable to your model). The Clear Parts, once mounted on the mounting tab, are difficult to remove from the tab. If the Clear Part must be removed, gently pry the Clear Part upward until loose. When mounting Window Frames, be careful that they are positioned correctly, according to the instructions of your specific model.
- Prior to assembly, brick areas can be enhanced by adding modeling mortar (if applicable for your model). We use Robert's Brick Mortar Formula. It's easy to apply and looks great. For product information, contact Robert's Products Co., P.O. Box 270057, Milwaukee, WI 53227.
- Use the full-color box lid as a helpful guide during assembly.
- Now it's time to break ground for the construction of your Cityscenes™ building. Take your time and have fun!

RECOMMENDED TOOLS

Modeling Knife - For removing parts from sprue and trimming.

Hobby File - For removing sprue marks.

Glue - Preferably a liquid, easy-to-brush adhesive. Use it sparingly.

3/8 - 1/2" Brush - Helpful in spreading glue on larger areas.

Tweezers - For assembling smaller parts.

Sandpaper or Emery Board - For removing flash.

ROOF WATER TANK

NOTE: The roof of this building is slanted towards the back wall. To assemble Water Tank “level,” cut approximately 2 mm off the bottom of two supports and place in desired location. Glue should be applied sparingly to all parts.

ASSEMBLE IN SEQUENCE:

1. Two pieces of Roof Support (18) to two pieces of Cross Braces (19).
2. Tank Base (17) to Braces (18) and (19).
3. Tank Top (20) to Tank Main Body (21).
4. Prior to final assembly of Tank to Base, allow glue on Base assembly to dry. After glue has dried, assemble Tank to Base.

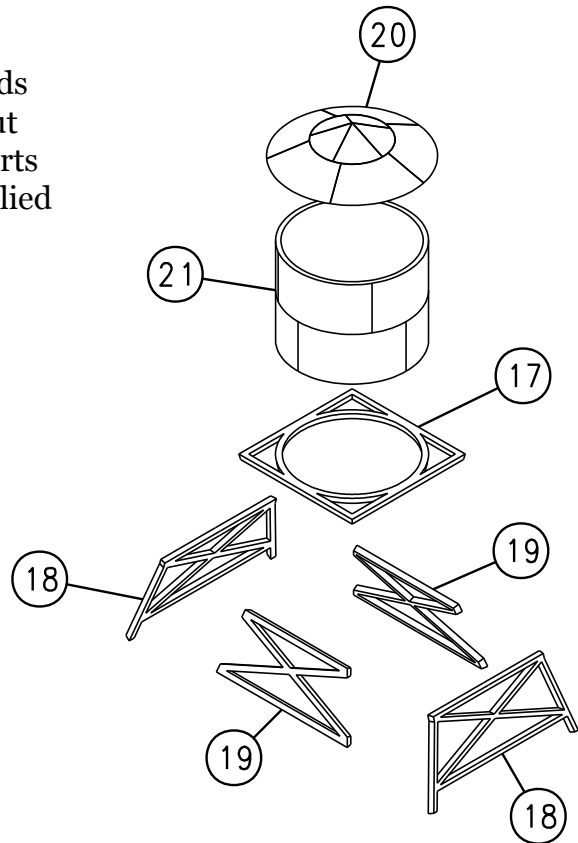

AFTER YOU COMPLETE THIS ASSEMBLY STEP, YOU WILL HAVE SOME PARTS LEFT OVER. THESE PARTS ARE NOT NEEDED. YOU MAY USE PARTS FOR SCRATCHBUILDING PROJECTS.

Decals

Custom decals have been included with your kit and can be applied at your discretion. Application directions are provided on the back of the decal envelope.

DAMAGED OR MISSING PARTS:

We take great care in ensuring that all parts are present and in good condition. In the unlikely event that a part is missing or damaged, our Service Department will be happy to assist you. For more information contact:



Service Department
Bachmann Industries, Inc.
1400 East Erie Avenue
Philadelphia, Pennsylvania 19124

Phone: 1-800-356-3910



Bachmann Industries, Inc., 1400 East Erie Avenue, Philadelphia, PA 19124
www.bachmanntrains.com
Printed in Denmark.