

#### A) Change the Tapered Stack to Diamond Stack

1. Unscrew the screw and remove the tapered stack
2. Assemble the diamond stack base and screw
3. Assemble the body shell of diamond stack

#### B) Change the Diamond Stack to Tapered Stack

1. Take off body shell of diamond stack
2. Unscrew the screw and remove the diamond stack base
3. Assemble the tapered stack and screw

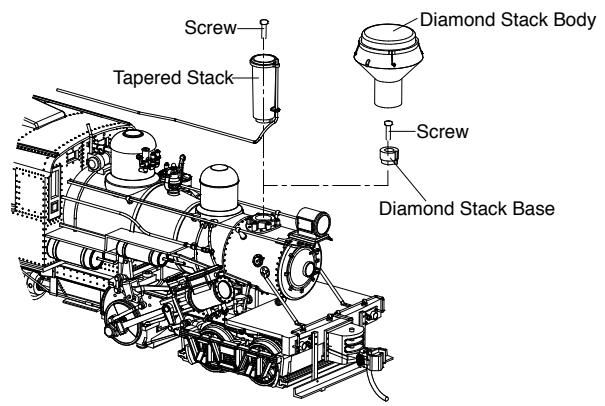

- For dummy plug installation:
- a) Remove the decoder,
  - b) install the dummy plugs by tool (see following diagram).

