

Please check the direction of the connector carefully before putting the wire connector into the connector housing. Please take care when inserting or unplugging the connector, making sure that it is straight and aligned before pushing into the connector housing. Otherwise, the pins in the housing may be deformed.

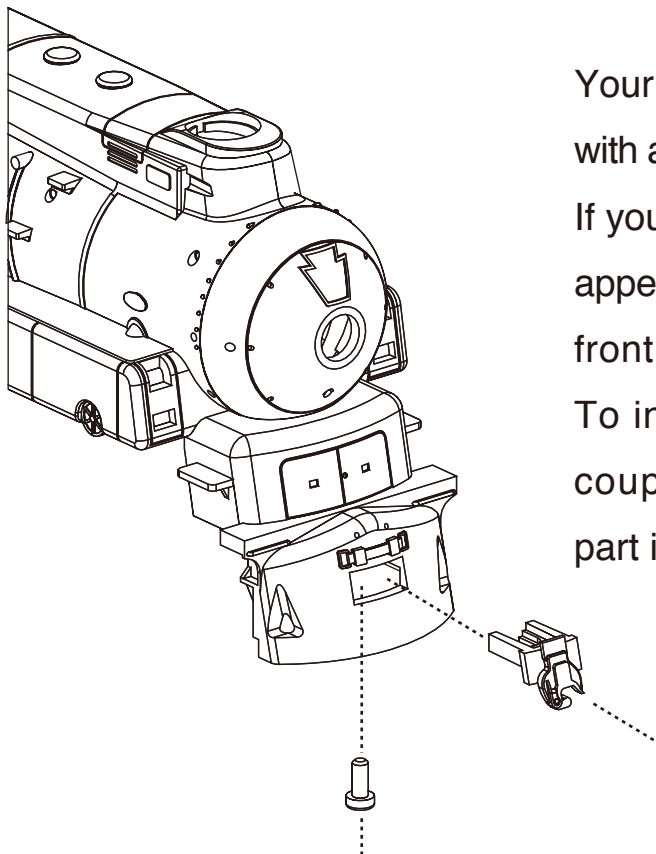
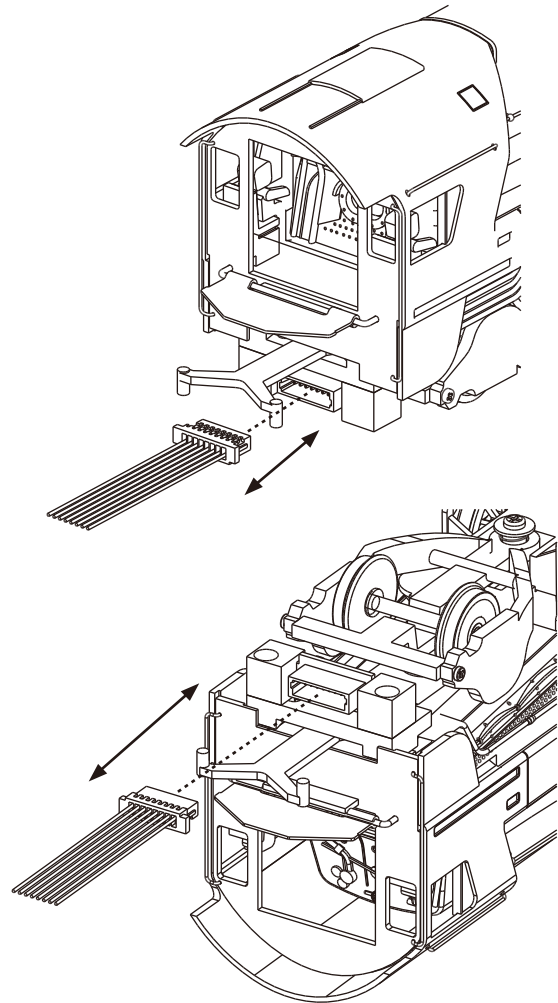

Your K-4 locomotive is shipped equipped with an E-Z Mate® Mark II operating coupler. If you wish to achieve a more streamlined appearance, there is dummy coupler for the front pilot included in the accessory bag. To install, simply remove the operating coupler and install the dummy coupler part in the pilot opening as shown.